

# IKA

designed for scientists

EN



TRADITION MEETS INNOVATION |  
The new Magnetic Stirrer series

## Progress On The Smallest Scale

### Innovation in Motion: The Evolution of IKA Magnetic Stirrers

For decades, IKA has been at the forefront of magnetic stirring technology, continuously setting new standards in precision, reliability, and design. Our commitment to innovation has transformed our magnetic stirrers into global bestsellers—trusted by laboratories and professionals around the world. With each new launch, we refine and enhance our products, integrating smarter features, improved performance, and user-centric design. The latest generation of IKA magnetic stirrers continues this legacy, offering even greater efficiency and control to meet the evolving needs of modern science.



1952

1992



1987



1970



1968



1994



2011



2022



2026



World's First Laboratory Device  
Manufactured by Robots

## Introducing the Next Generation of Magnetic Stirrers – Powered by RoboMAG

For decades, IKA has shaped the future of magnetic stirring technology. Our devices have become global standards – recognized for exceptional precision, long-lasting reliability, and unmistakable design. With every new product generation, we build upon this heritage: refining performance, enhancing safety, and integrating intelligent features that make everyday laboratory work easier, faster, and more efficient. Today, we elevate that legacy once again.

## A World First: Laboratory Devices Produced by Robots

The latest IKA Magnetic Stirrer line is manufactured using RoboMag, the world's first fully automated production line for laboratory devices. This groundbreaking approach combines German engineering with robotic precision, ensuring consistent quality that human-only production simply cannot match.



## “MADE IN GERMANY” – Reinvented

RoboMag brings together state-of-the-art robotics, advanced quality control, and decades of IKA expertise. Every device is assembled, calibrated, and tested automatically, each unit held to the same uncompromising standards. The result is unmatched repeatability, flawless consistency, and a new benchmark for laboratory equipment manufacturing.

## Uncompromising Safety and Quality

Every magnetic stirrer undergoes 100% automated testing, ensuring full standards compliance and maximum operational safety. From motor performance to temperature resistance to long-term reliability simulations, no unit leaves the line without passing a rigorous series of inspections.

### YOUR BENEFITS

- › Higher product safety
- › Longer service life
- › Zero production variance
- › Reliable performance in every lab, every day

## Engineering the Future of Smart Stirring

The new magnetic stirrer generation is smarter, more energy-efficient, and more responsive than ever – designed for the evolving demands of modern science and high-throughput workflows.

With RoboMag, IKA sets a new industry standard. Not just for magnetic stirrers, but for how scientific instruments should be built. For maximum safety and a long service life.



## New Magnetic Stirrers RCT and RET

New Design, Even More Features



### Compact Design and smallest footprint on the market

By minimizing the footprint with a plate size of still 135 mm, it is the smallest magnetic stirrer on the market – for improved workflows, safer working conditions and reduced equipment and operating costs. The compact design fits easily into fume hoods and tight lab spaces, making it ideal for parallel setups with multiple stirrers.

### Performance Meets Durability

- › Up to 340°C heating
- › Speeds up to 1700 rpm
- › Brilliant, chemically resistant glass display
- › Robust die-cast aluminum housing: fireproof, durable, and stable
- › Flexibly programmable timer with acoustic signal

Built for long-term use and reliable lab performance.

### Operating Modes

The magnetic stirrer offers flexible operating modes to control behavior after power-up and access to setpoints.

**Mode A:** ensures set values are not saved after power interruption

**Mode B:** resumes the last set values

**Mode C:** restricts setpoint changes

**Mode D:** requires confirmation for any adjustments

**Mode R:** resumes the last operating state and set values after power interruption



### Double Sensor Application for medium and carrier medium

Up to two temperature sensors (wired and wireless) can be connected – for redundant or spatially differentiated monitoring, e.g. of a carrier medium. This function can be activated through USB-Bluetooth connection (already integrated in RET model).

### Super Robust Design – IP 54 Protection

- › Sealed housing resists aggressive vapors & liquids
- › High-quality glass display cover
- › Silicone-capped interfaces for added protection
- › Built to last – even in harsh lab environments

### Excellent Magnetic Connection

- › High-performance AlNiCo magnet positioned close to the heating plate
- › Ensures strong coupling with the stirring bar



RCT basic  
Ident. No. 0025008259

### Brushless EC Motor

- › Durable & maintenance-free
- › Soft start protects from stirring bar detaching
- › Precise control for reproducible results

## Fast & Efficient Heating

With 800 W of power and superior plate insulation, your samples heat up faster and reach higher temperatures - even in large volumes.

For applications requiring gentle temperature control, the heat output can be adjusted in four steps. This allows for slow and controlled heating, ideal for sensitive samples or gradual reaction setups.

## Two Mounting Options for Stands

With two integrated mounting points for support rods, test setups can be arranged flexibly and securely. Sensors can be positioned precisely without the need for bulky additional fixtures, saving valuable space in the fume hood and allowing for more efficient experimental layouts.



### ① Coated Aluminum Plate (optional)

- › Black anodized finish: scratch- and chemical-resistant durable surface, even with long-term use
- › Aluminum core: ensures even heat distribution and fast energy transfer

## Temperature Modes for Synthesis Blocks

Different applications demand different temperature control strategies. FAST mode heats insensitive substances quickly, allowing for temperature overshoots. Precise Mode is designed for sensitive reactions where overshoots must be avoided. Three different BLOCK modes ensure precise control when using IKA synthesis attachments, especially in systems with buffered energy transfer.

RET basic anodized  
Ident. No. 0020133787

## Effortless Navigation and Customizable Display

Enjoy intuitive operation with a clear 14-segment LED display and simple menu navigation. While clear icons indicate active functions, advanced settings are easily accessible without complex key combinations, ensuring quick, user-friendly navigation and full control. The integrated Key Lock function prevents inadvertent changes of speed and temperature settings.

Customize what you see: stirrer speed, temperature readings, pH value, or timer. Stay focused on the data that matters most and streamline your workflow with ultimate flexibility.

## Perfect Fit for Lab Lifting Platforms

- › Designed to match standard 200 × 200 mm lab lifting tables
- › No need for new equipment - more space in the fume hood
- › Seamless integration with existing setups



Ident. No. 0004022400



## The Difference between the RCT and RET model

The **RCT** represents a new laboratory standard, delivering top-level precision, safety, and ease of use for all conventional laboratory applications. It sets the benchmark for modern daily lab work.

The **RET**, on the other hand, is designed for customers aiming to move toward automation and Laboratory 4.0. With advanced connectivity, intelligent interfaces, and seamless integration into digital workflows, it enables fully networked and automated processes.

Technical Features	RCT basic	RET basic
Max. Temperature (Room temp. + device self heating)	310 °C	340 °C
Max. stirring quantity (H <sub>2</sub> O)	20 l	20 l
Speed	50 – 1500 rpm	50 – 1700 rpm
Ethernet / Wifi	No	Yes
Adjustable safety circuit	50 – 360 °C	50 – 360 °C
Connection for ext. temperature sensor	PT1000, ETS-D5, ETS-D7, PT wireless	PT1000, ETS-D5, ETS-D7, PT wireless
Wireless Sensors	Dongle	Yes
Dimensions (W × H × D)	160 × 100 × 200 mm	160 × 100 × 200 mm
Set-up plate dimensions	Ø 135 mm	Ø 135 mm
Device to Device Communication	Yes	Yes
IKA Lab Assistant (App)	Dongle	Yes
IKA Lab Monitor (Cloud)	No	Yes
Double Sensor Functionality	Yes (USB or Dongle)	Yes
Protection class acc. to DIN EN 60529	IP 54	IP 54

## Versatile Connectivity

Differences between RCT and RET basic

With USB-C and RS232 interfaces, the RET basic connects easily to a PC for remote control and data management.

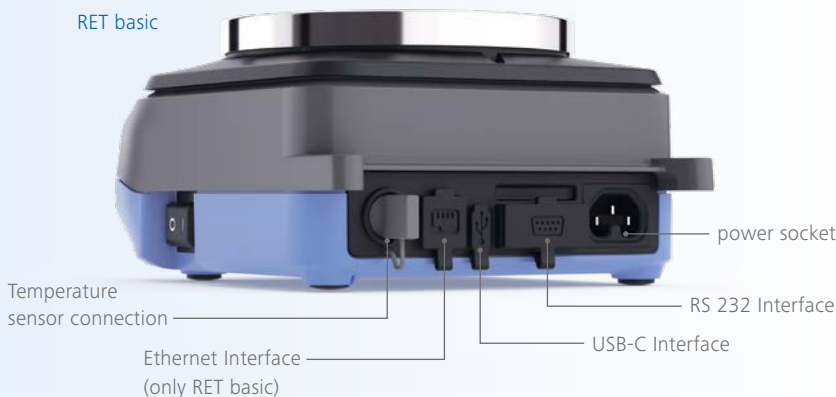

**RET basic**

Ident. No. 0025008265

**RET basic anodized**

Ident. No. 0020133787

## Smart Temperature Control via Wireless Communication

We take care of 24/7 operation—even for complex applications. When connected via USB Dongle\* (available as accessory), the magnetic stirrer communicates wirelessly with IKA overhead stirrers to safely control temperature in “heating only” mode. This setup is ideal for viscous samples that can’t be stirred magnetically, preventing overheating, boiling delays, and hot spots by switching off heating if stirrer speed drops below a defined threshold.

This advanced function is already integrated in the **RET basic model**, enabling cost-effective and unattended operation of combined heating and stirring setups—without requiring additional technical effort.

### YOUR BENEFITS

- › Safe, unattended operation of complex setups
- › Cost-effective solution without extra equipment
- › Reliable temperature control for sensitive samples

\*only required for RCT basic. Already integrated in RET basic model.



## Ready for Industry 4.0

## Smart Connectivity for Modern Labs

With the IKA Lab Assistant (App), you can monitor device values remotely, while the IKA Lab Monitor (Cloud) enables secure data storage and access from anywhere.



## Centralized Control with IKA HUB

The IKA HUB acts as a central interface, connecting and managing multiple devices for streamlined workflows and enhanced lab efficiency.

IKA HUB  
Ident. No. 0020123598



# Automation Made Easy

Lab Assistant, Lab Monitor und Hub

RET basic

Ident. No. 0025008265

Connect your device to the IKA Lab Monitor (Cloud) and IKA Lab Assistant (App)



Additionally to the features of the RCT basic, the new RET basic model comes with:

## Integrated Wireless Connection

For the first time, the device features a fully integrated wireless connection, enabling seamless communication with external sensors and smart accessories. This breakthrough allows effortless pairing and real-time data transfer without the need for additional hardware.

The feature is already supported by the IKA Lab Assistant, ensuring intuitive setup, monitoring, and documentation.

### YOUR BENEFITS

- › Flexible wireless integration
- › Easy connectivity with lab tools

First on the market

## Ethernet Connectivity

Equipped with an RJ45 port with LED, the device supports stable wired network connections for reliable data transfer and integration.

### YOUR BENEFITS

- › Secure, high-speed communication
- › Easy integration into lab networks
- › Enhanced connectivity options



## Because Safety is in our DNA

### Safety First with IKA Magnetic Stirrers

When working with flammable liquids, laboratory equipment must meet the highest safety standards. IKA magnetic stirrers are designed with exactly that in mind. All our devices are NRTL-certified by TÜV and comply with strict safety, performance, and regulatory requirements. They also meet commonly used international standards, including CE certification and DIN IEC EN 61010-1.

#### Independent Safety Circuit

High temperatures are often experienced during laboratory work with magnetic stirrers. This is precisely where special safety precautions are required. Our safety concept Integrated Safety protects the sample, laboratory, and the user, ensuring a successful outcome for your experiment. With IKA, you can rely on maximum safety at every step of your workflow.

#### Hot Plate Warning

It is not possible to tell whether a heating plate is hot. If the heating function has been switched off, RCT and RET basic automatically issues a warning if the plate temperature exceeds 50°C. This also works when the device has been switched off, providing reliable protection against burns.

#### Continuous Stirring in Case of Error

In the event of an error or activation of a safety shutdown, the magnetic stirrer maintains its stirring function without interruption. This feature reliably prevents boiling delays, ensuring consistent mixing and reducing the risk of sudden reactions or overheating due to stagnant conditions.

#### INTEGRATED SAFETY INCLUDES THE FOLLOWING FEATURES

- › **Independent control circuit for overheating protection** to ensure that the critical temperature of the medium can never be exceeded – even when the temperature sensor in the medium or in the heating element is defective or fails completely.
- › **Custom safety temperature** to individually set the maximum temperature allowed depending on the sample.
- › **Locking function** to prevent accidental changes to the set speed and temperature values.
- › **Temperature warning** to inform the user that the plate is still hot.
- › **Automatic self-monitoring function** of all safety-relevant components, in case of breakdown.
- › **The Heating and Stirring functions** can be completely deactivated in the menu.
- › **Detection of rapid temperature drop** for early indication of potential issues.



## Protection of Medium

### Delta T Safety Function

In certain laboratory applications, the medium temperature must approach its flash point — a scenario that demands heightened safety measures. In these cases, the heating plate temperature may exceed the medium's flash point, which is permissible only under strict safety protocols and thorough risk assessments.

To prevent the medium from overheating, IKA magnetic stirrers feature a **Delta T safety function**:

- › If the measured medium temperature exceeds the setpoint by a defined temperature difference ( $\Delta T$ ), the device automatically switches off the heating.
- › Heating remains disabled until the device is manually restarted, ensuring full control and safety.

This function allows users to define a custom safety threshold, adding an extra layer of protection when working with sensitive or flammable substances.

#### YOUR BENEFITS

- › Customizable temperature difference ( $\Delta T$ )
- › Automatic heating shutdown
- › Manual restart for added control
- › Ideal for high-risk applications

### Detect sudden temperature drops

In laboratory environments, sudden temperature drops can signal serious issues—such as **glass breakage**, which may expose temperature sensors to air. These events can compromise safety and the integrity of your experiment.

IKA magnetic stirrers are equipped to **detect abrupt temperature drops** in the medium and respond accordingly:

- › The device continuously monitors the medium temperature.
- › If a sudden drop is detected, the stirrer can be configured to **shut down permanently** to prevent further risk.
- › Users can **customize the device behavior** directly via the menu settings.

This feature adds another layer of protection, especially in sensitive or high-risk applications.



## Reliable detection of missing temperature increase

In some cases, a **temperature sensor may be incorrectly positioned**, causing the system to receive no accurate feedback from the medium—even though the heater is actively supplying energy. This can lead to overheating and safety risks.

The **IKA RCT basic and RET basic** magnetic stirrers includes a safety feature that detects when no temperature increase occurs despite continuous heating:

- › If the medium temperature remains unchanged over time, the device **automatically switches off the heater**.
- › This prevents uncontrolled heating and protects both the sample and the equipment.

This intelligent function ensures that your heating process is not only efficient but also **safe and responsive to real-world conditions**.

## Medium Temperature Limits

To ensure safe operation and protect sensitive materials, the temperature of the medium can be restricted via the software. Users are prevented from setting temperature values beyond the defined safety limits. This feature helps avoid overheating and ensures compliance with process requirements.

## Carrier Temperature Limits

When two temperature sensors are used, the system allows for independent temperature limits to be set for both the medium and the carrier medium (e.g., oil bath or synthesis block). Carrier media typically represent the hottest surfaces that could come into contact with the reaction medium—especially in cases of glass breakage.

By setting a maximum temperature for the carrier, the system ensures that critical thresholds are not exceeded, adding an extra layer of safety to protect both the sample and the equipment.

## Smart Communication for the Modern Lab

The RET basic connects directly with overhead stirrers via USB-C or RS232, forming a smart heating–stirring duo ideal for high-viscosity or changing-viscosity processes. Many reactants begin with a viscosity that is too high for a magnetic stir bar or become significantly more viscous during the reaction (e.g., polymerization). In these cases, the combination of both devices is the perfect match.

Once connected, the RET automatically reads the stirring speed of the overhead stirrer and uses this information to safeguard the process. A minimum speed limit can be defined on the RET—if the overhead stirrer cannot maintain that speed, the RET immediately stops heating. This prevents burning, overheating, and thermal runaway, even in difficult media.

Together, the RET and overhead stirrer enable safer heating, smarter control, and reliable 24/7 unattended operation, making the IKA setup uniquely suited for modern, automated laboratories.



## Double Temperature Sensor for Enhanced Safety in Carrier Applications

Dual Temperature Sensor System for Maximum Safety and Precision  
 IKA magnetic stirrers are equipped with a dual-sensor temperature safety system designed to ensure both operational accuracy and reliable protection during temperature-sensitive or flammable applications.  
 Integrated Device Sensors  
 Two independent temperature sensors are built beneath the heating plate:

**Sensor 1:** Controls and regulates the heating plate temperature.

**Sensor 2:** Monitors a critical safety temperature (e.g., the medium's flash point) and triggers an automatic shutdown before hazardous conditions can develop.

The safety circuit associated with Sensor 2 is fully independent of the heating setpoint and can be adjusted directly on the device using a simple tool (e.g., a screwdriver).

External Sensor Options

For precise process monitoring, the system also supports:

**PT 1000 Sensor:** Measures temperature directly inside the reaction medium (e.g., a liquid in a beaker or flask).

**Wireless Sensor:** Monitors the temperature of the carrier medium (such as an oil bath or synthesis block) or a second point within the same medium.

This flexible setup enables simultaneous monitoring of both the reaction medium and its surrounding environment, ensuring consistent conditions and preventing overheating.

### YOUR BENEFITS

- › Compliant with EN IEC 61010-2-010
- › Independent, adjustable safety circuit
- › Optimized protection for flammable liquids
- › Real-time monitoring of multiple temperature zones
- › User-friendly configuration and setup



## New intelligent Temperature Sensors

Wireless Communication with Temperature and pH Sensors

Expand your capabilities without extra devices. With the wireless sensors PT.Wireless and the advanced Wireless Sensor ETS-D7, your magnetic stirrer transforms into a **pH meter**—no separate device required. Simply connect pH electrodes with BNC connectors directly to the stirrer, saving valuable space and reducing costs.

Unlock an additional high-end function with the sensor—functionality that would otherwise require expensive equipment and extra space. This smart integration makes your lab more efficient and cost-effective.

### YOUR BENEFITS

- › Integrated pH measurement
- › No extra equipment required

Fully functional standalone pH Meter

### PT wireless sensor

- › Wireless connection (Bluetooth)
- › Changeable temperature sensor
- › Connection of pH electrode possible
- › Rechargeable battery for 150 working hours
- › USB-C

Connected to the HUB or IKA Lab Assistant, it becomes a standalone pH meter and offers seamless integration and space-saving functionality.



Combinable with IKA Lab Assistant or IKA HUB to have an additional display for a better overview of your workflow.



## Combination with ETS-D7 Wireless Sensor

Integrating the ETS-D7 with the RCT basic or RET basic magnetic stirrer offers advanced temperature measurement and readability:

- › Enhanced Display Resolution: Temperature readings are shown with a resolution of  $\pm 0.01$  K, allowing for highly accurate monitoring.
- › Dual Control Interface: Setpoints can be configured either on the magnetic stirrer or directly on the ETS-D7. The values are automatically synchronized between both devices, ensuring seamless operation and eliminating discrepancies.
- › Rechargeable battery for 40 working hours (display 100% on), 80 working hours (display 50% on).





## Combination with ETS-D5 Contact Thermometer

Pairing the RCT basic or RET basic Magnetic Stirrers with the ETS-D5 contact thermometer introduces an additional, independent safety circuit for temperature limitation in the medium. This setup enhances process safety and precision by:

- › Advanced Temperature control: ETS-D5 takes full control of your process with enhanced temperature control for even better accuracy.
- › Direct Temperature Display: The temperature is shown exactly at the point of measurement, eliminating any potential confusion.
- › Eye-Level Readability: The 2" display is positioned for easy viewing, allowing users to quickly check both setpoint and actual temperatures.
- › Improved Accuracy: The ETS-D5 increases display resolution and setting accuracy from  $\pm 1$  K to  $\pm 0.1$  K—especially beneficial for handling critical or sensitive media.

## COMPLETE SOLUTIONS

### RCT basic ready-to-go

The complete solution RCT basic ready-to-go contains all components for safe and effective sample temperature control:

RCT basic ready-to-go  
Ident. No. 0010016459



#### Scope of delivery

0025008259	RCT basic magnetic stirrer incl.
0003516800	PT 1000.60 Temperature sensor
0001545100	H 16 V Support rod
0002437700	H 44 Boss head clamp
0003547700	H 38 Holding rod
0020003417	BC 1000 Beaker cap



Also available as  
anodized version

### RCT basic ETS-D5 Solution

The ETS-D5 electronic contact thermometer makes your RCT basic even safer:

- › Additional safety monitoring: If a defined temperature value in the medium is exceeded, the magnetic stirrer switches to a safe state. The independent safety circuit for controlling the maximum temperature of the hotplate is of course maintained.
- › Temperature control accurate to a tenth of a degree
- › Additional display at eye level

RCT basic ETS-D5 Solution  
Ident. No. 0010016495



#### Scope of delivery

0025008259	RCT basic Magnetic stirrer
0025008371	ETS-D5 Contact thermometer
0001545100	H 16 V Support rod
0002437700	H 44 Boss head clamp
0003547700	H 38 Holding rod



Also available as  
anodized version

## RCT basic Synthesis Solutions

The reaction block enables synthesis in round-bottom flasks at temperatures of up to 300 °C and replaces processes using oil baths.

This system ensures optimum heat transfer from the hotplate directly into the medium. Magnetic stirring bars in an elliptical shape, which are adapted to the geometry of round bottom flasks, ensure perfect mixing. When switching from oil baths to IKA synthesis blocks, the risk potential can be significantly reduced and the handling and cleaning of the round-bottom flasks significantly simplified.

RCT basic Synthesis Solution 250 / 500 / 1000

Ident. No. 0010016490 / 0010016483 / 0010016478



### Scope of delivery

0025008369	PT Wireless
0020123620	USB WD
0025008259	RCT basic magnetic stirrer incl.
0003516800	PT 1000.60 Temperature sensor
0025003280	Flask carrier 250 / 500 / 1000 ml
0001545100	H 16 V Support rod
0002437700	H 44 Boss head clamp (2 pcs.)
0001752900	R 350 Universal clamp
0003547700	H 38 Holding rod
0004494800	Magnetic stirring bar IKAFLON 25 / 30 / 40 ellipse

\*Attractive total price compared to the sum of individual prices.



Ident. No	Name
0010016508	RCT basic ETS-D7 Solution
0010016513	RCT basic PT wireless Solution

More Solutions  
available at  
[www.ika.com](http://www.ika.com)

## RH lite and RH basic Magnetic Stirrer

The Entry-Models



RH lite

Ident. No. 0020007108



### Simple. Compact. Reliable.

The new RH lite is the perfect solution for entering the world of magnetic stirrers. It impresses with its compact design and high-quality at an affordable price. Developed for simple applications and basic laboratory needs, it combines an attractive price-performance ratio with solid quality and clever functionality. RH lite offers everything you need for safe and efficient work.

### For simple applications

The RH lite deliberately does not have external temperature control. For simple applications, this is not only sufficient, but also an advantage: less complexity, lower costs, and yet complete safety thanks to the integrated temperature safety circuit. This makes the RH lite the ideal choice for basic processes where direct temperature control of the heating plate is completely sufficient.

### The smart basis for your laboratory

The RH lite is the perfect entry-level magnetic stirrer: compact, powerful, and safe—without unnecessary extras, but with everything you need for simple and reliable applications. RH lite offers everything you need for safe and efficient work.

### High performance for excellent value

- › Adjustable safety temperature circuit, compliant with EN IEC 61010-2-010
- › Intuitive control: Two push / turn knobs for independent setpoints and start / stop of heating and stirring.
- › High performance heating of 600 W heater and a robust 135 mm aluminum hotplate.
- › Strong stirring performance of up to 310 °C and 1,500 rpm.
- › Energy-efficient EC motor for powerful stirring with low energy consumption.
- › Extremely compact footprint with only 168 × 217 mm — ideal for tight workspaces.
- › Low self-heating makes it perfect for temperature-sensitive samples.
- › Two support rod mounts for flexible setups and secure sensor positioning.

## Precision in Motion with the RH basic

Uncompromised performance in a sleek design

The new RH basic is the ideal choice for anyone who needs a compact yet powerful magnetic stirrer with reliable temperature control. Building on the RH lite, it offers all the benefits of its sister model while adding professional **external temperature regulation** thanks to an **integrated sensor interface** and the **included ETS-D5 contact thermometer**.

## Connect to Contact Thermometer ETS-D5

The included ETS-D5 turns the RH basic into a precise, safe temperature-controlled heating and stirring system.

- › High-precision control: 0.1 K resolution and accurate regulation directly in the sample.
- › Stable PID performance: Smooth heating without overshoot.
- › Strong safety package: Automatic shutdown on sensor errors, safety-temperature exceedance, sensor timeout, temperature-drop detection, and setpoint limits.
- › Flexible sensor options: Exchangeable probe, also available with special coatings.
- › Three control modes: Fast, Precise, and Synthesis Block.
- › Adjustable heating rate for sensitive samples.
- › Easy operation: Intuitive touch display and USB-C data transfer.



RH basic

Ident. No. 0020106987

### Scope of delivery

0020106987	RH basic Magnetic stirrer
0025008371	ETS-D5 Contact Thermometer
0003547700	H 38 Holding rod
0002437700	H 44 Boss head clamp
0001545100	H 16 V Support rod



designed for scientists

# Everything for Your Lab

IKA is your reliable partner in laboratory, analysis and process technology. When it comes to applications in the areas of stirring, mixing, tempering, distilling or grinding, market leaders rely on our proven products and technology. We are continually working to further develop our portfolio according to the needs of our customers. Building on this, we network our products and services to create holistic, application-oriented solutions and enable our customers to achieve the best possible results and step into the digital age.



BIOREACTORS



MIXING



HEATING / COOLING /  
TEMPERING



LIQUID HANDLING



MEASURING VISCOSITY



VACUUM TECHNOLOGY



CRUSHING



DIGITAL LAB SERVICES



SEPARATION



ELECTROCHEMISTRY



REACTOR SYSTEMS



CALORIMETRY

**IKA-Werke GmbH & Co. KG**  
Janke & Kunkel-Straße 10,  
79219 Staufen, Deutschland  
+49 7633 831-0 / sales@ika.de



IKAworlwide// #lookattheblue



Stay up to date:  
[www.ika.com/  
newsletter](http://www.ika.com/newsletter)

Technical specifications are subject to  
change without notice.  
Information on delivery not binding.