



**Nederman**



# Nederman Catalog

Laboratory Extraction



# Table of content

## EXTRACTION, ARMS FX

|                                          |    |
|------------------------------------------|----|
| BenchTop Extraction Arm FX2 75 CHEM      | 3  |
| BenchTop Extraction Arm FX2 50 ESD/EX    | 6  |
| BenchTop Extraction Arm FX2 100 CHEM     | 9  |
| BenchTop Extraction Arm FX2 75 ESD/EX    | 12 |
| BenchTop Extraction Arm FX2 100 ESD/EX   | 15 |
| BenchTop Extraction Arm FX2 75 Original  | 18 |
| BenchTop Extraction Arm FX2 100 Original | 21 |
| BenchTop Extraction Arm FX2 50 Original  | 24 |
| Bench Top Extraction arm FX32 Original   | 27 |
| Bench Top Extraction arm FX32 ESD        | 28 |



# Capture and Extraction Units



# BenchTop Extraction Arm FX2 75 CHEM

The best and most cost-efficient solution for extraction of hazardous airborne contaminants, in applications where small, flexible and easy-to-use arms are required.

Nederman FX2 arms are made of lightweight anodized aluminium sections, with three adjustable, composite friction joints. Offering strength and durability combined with easy handling, they can be used in many types of environment. They are especially suitable for applications where small, flexible and easy-to-use arms are required. With the profiles made of anodized aluminum with a white electrophoretic deposition coating, the arm is ideal for fume extraction in aggressive environments where corrosion resistance must be assured.

- Optimal efficiency and low noise provides safe and quiet working environment
- Ceilings, walls and floors or fixed to worktops mountings and cut2fit extension profile gives maximum installation flexibility
- The two outermost arm joints can rotate and swivel through 360°, which gives the unique maneuverability
- The lean, smooth and aesthetic design allows arms to fit in well in any environment without compromising its durability and reliability
- Highly integrated products that save customers' time and costs, as well as providing the reliability and functionality to deliver a better performance







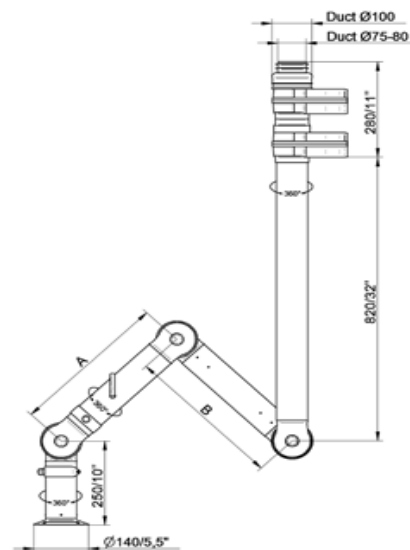



• FX2-CHEM-D75-L1100-Up-PLUS  
 Part number: 70603244  
 Max. working radius: 1090 mm (42,9 in)  
 A: 420 mm (16,5 in)  
 B: 420 mm (16,5 in)

• FX2-CHEM-D75-L1500-Up-PLUS  
 Part number: 70603644  
 Max. working radius: 1450 mm (57,1 in)  
 A: 500 mm (19,7 in)  
 B: 700 mm (27,5 in)























## Models

|                                                                                     | Description                 | Weight (kg) | Item Number |
|-------------------------------------------------------------------------------------|-----------------------------|-------------|-------------|
|  | FX2-CHEM-D75-L1100-Down-Low | 3,2         | 70603144    |

|                                                                                   | Description                     | Weight (kg) | Item Number |
|-----------------------------------------------------------------------------------|---------------------------------|-------------|-------------|
|  | FX2-CHEM-D75-L1100-Up-PLUS      | 4,5         | 70603244    |
|  | FX2-CHEM-D75-L1100-Down-Through | 3,2         | 70603344    |
|  | FX2-ORIG-D75-L1500-Up-Low       | 2,6         | 70603444    |
|  | FX2-ESD/EX-D75-L1500-Down-Low   | 3,4         | 70603544    |
|  | FX2-CHEM-D75-L1500-Up-PLUS      | 4,7         | 70603644    |
|  | FX2-CHEM-D75-L1500-Down-Through | 3,4         | 70603744    |
|  | FX2-ESD/EX-D75-L1100-Up-Low     | 2,8         | 70603844    |

## Accessories

|                                                                                     |                                     | Item Number |
|-------------------------------------------------------------------------------------|-------------------------------------|-------------|
|    | FX2-Bench bracket kit-D50/75/100    | 70501444    |
|   | FX-Ceiling cover plate              | 70502644    |
|  | FX2-Ceiling cover plate-PLUS        | 70377045    |
|  | FX2-Wall BRKT kit-Flat-L190-White   | 70377043    |
|  | FX2-Bracket kit-D50/75/100-L500     | 70377042    |
|  | FX-Bracket kit-D50/75/100-L190      | 70501144    |
|  | FX2-Wall-P BRKT kit-D50/75/100-L190 | 70377046    |
|  | FX-Classic bracket-D50/75/100       | 70501244    |
|  | FX-Cut2fit extension-L1100          | 70501344    |
|  | FX-Cut2fit extension-L2200          | 70374600    |
|  | FX2-Hose support ring-D75           | 70377067    |
|  | FX2-Hose support ring-D100          | 70377068    |
|  | FX2-Al duct-L1000-D75/100toD100-WHT | 70377054    |
|  | FX2-Al duct-L2000-D75/100toD100-WHT | 70377055    |
|  | FX-Metal hood-ORIG/CHEM-D50/75/100  | 70500444    |
|  | FX-Combi hood-CHEM-D50/75/100       | 70500344    |
|  | FX-Dome hood-CHEM-D50/75/100        | 70376984    |

|                                                                                   |                                   | Item Number |
|-----------------------------------------------------------------------------------|-----------------------------------|-------------|
|  | FX-Flange hood-CHEM-D50/75/100    | 70503044    |
|  | FX-Hose-D75-L3000-Grey            | 70377098    |
|  | FX-Hose-D100-L3000-Grey           | 70377099    |
|  | FX2-Duct connector-ORIG/CHEM-D100 | 70377040    |

# BenchTop Extraction Arm FX2 50 ESD/EX

**The best and most cost-efficient solution for extraction of hazardous airborne contaminants, in applications where small, flexible and easy-to-use arms are required.**

Nederman FX2 arms are made of lightweight anodized aluminium sections, with two or three adjustable, composite friction joints. Offering strength and durability combined with easy handling, they can be used in many types of environment. They are especially suitable for applications where small, flexible and easy-to-use arms are required. The arm is designed for use in electronic environments where there is a risk of electrostatic discharges. The ESD/EX can also be used for certain applications in potentially explosive atmospheres.

- **Optimal efficiency and low noise provides safe and quiet working environment**
- **Ceilings, walls and floors or fixed to worktops mountings and cut2fit extension profile gives maximum installation flexibility**
- **The two outermost arm joints can rotate and swivel through 360°, which gives the unique maneuverability**
- **The lean, smooth and aesthetic design allows arms to fit in well in any environment without compromising its durability and reliability**
- **Highly integrated products that save customers' time and costs, as well as providing the reliability and functionality to deliver a better performance**







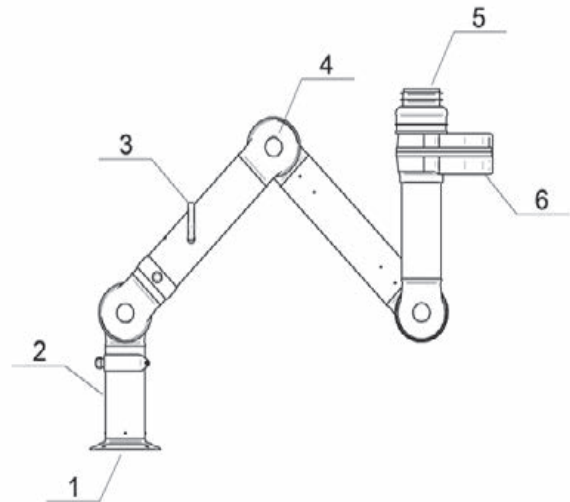



## Material:

















- 1) Flange: Conductive PP plastic
- 2) Tubes: Aluminum, anodized 10 µm
- 3) Damper adjustment handle: Aluminum: anodized 10 µm  
Internal spring: Stainless steel  
Damper blade: Conductive TP & PP plastic
- 4) Joints conductive: PP plastic with glass fibre reinforcement  
Plastic rings conductive: PP plastic with glass fibre reinforcement  
Axial locking rings conductive: PP plastic with glass fibre reinforcement  
Adjustment knobs: PA & EDS plastic  
Threaded shaft inside joints: Stainless Steel
- 5) Duct connector: conductive EPDM Rubber
- 6) Swivel: Aluminum, conductive powder coating  
Rivets: Aluminum  
Bearings swivel conductive: PP plastic with glass fibre reinforcement





## Models

|                                                                                   | Description                         | Weight (kg) | Item Number |
|-----------------------------------------------------------------------------------|-------------------------------------|-------------|-------------|
|  | FX2-ESD/EX-D50-L700-Up/Down-Through | 1,7         | 70601244    |
|  | FX2-ESD/EX-D50-L1100-Down-Low       | 1,2         | 70601444    |
|  | FX2-ESD/EX-D50-L1500-Down-Through   | 2,3         | 70601544    |
|  | FX2-ESD/EX-D50-L1100-Down-Through   | 2,3         | 70601744    |
|  | FX2-ESD/EX-D50-L1500-Up-Low         | 1,8         | 70601844    |
|  | FX2-ESD/EX-D50-L1100-Up-Low         | 2,6         | 70601944    |
|  | FX2-ORIG-D75-L1100-Up-Low           | 2,6         | 70602144    |
|  | FX2-ESD/EX-D50-L1500-Down-Low       | 2,1         | 70602244    |

## Accessories

|                                                                                     |                                   | Item Number |
|-------------------------------------------------------------------------------------|-----------------------------------|-------------|
|   | FX2-Bench bracket kit-D50/75/100  | 70501444    |
|  | FX-Ceiling cover plate            | 70502644    |
|  | FX2-Ceiling cover plate-PLUS      | 70377045    |
|  | FX2-Bracket kit-D50/75/100-L500   | 70377042    |
|  | FX2-Wall BRKT kit-Flat-L190-Black | 70377044    |
|  | FX-Bracket kit-D50/75/100-L190    | 70501144    |
|  | FX-Classic bracket-D50/75/100     | 70501244    |
|  | FX-Cut2fit extension-L1100        | 70501344    |
|  | FX-Cut2fit extension-L2200        | 70374600    |
|  | FX-Dome hood-ESD/EX-D50/75/100    | 70376983    |
|  | FX-Combi hood-ESD/EX-D50/75/100   | 70500244    |
|  | FX-Metal hood-ESD/EX-D50/75/100   | 70500544    |
|  | FX-Flange hood-ESD/EX-D50/75/100  | 70502944    |
|  | FX2-Al duct-L1000-D50toD77        | 70377056    |
|  | FX2-Al duct-L2000-D50toD77        | 70377057    |
|  | FX2-Hose support ring-D75         | 70377067    |

|                                                                                   |                               | Item Number |
|-----------------------------------------------------------------------------------|-------------------------------|-------------|
|  | FX-Hose-ESD-D75-L3000-Black   | 70377101    |
|  | FX2-Duct connector-ESD/EX-D50 | 70377037    |

# BenchTop Extraction Arm FX2 100 CHEM

The best and most cost-efficient solution for extraction of hazardous airborne contaminants, in applications where small, flexible and easy-to-use arms are required.

Nederman FX2 arms are made of lightweight anodized aluminium sections, with three adjustable, composite friction joints. Offering strength and durability combined with easy handling, they can be used in many types of environment. They are especially suitable for applications where small, flexible and easy-to-use arms are required. With the profiles made of anodized aluminum with a white electrophoretic deposition coating, the arm is ideal for fume extraction in aggressive environments where corrosion resistance must be assured.

- Optimal efficiency and low noise provides safe and quiet working environment
- Ceilings, walls and floors or fixed to worktops mountings and cut2fit extension profile gives maximum installation flexibility
- The two outermost arm joints can rotate and swivel through 360°, which gives the unique maneuverability
- The lean, smooth and aesthetic design allows arms to fit in well in any environment without compromising its durability and reliability
- Highly integrated products that save customers' time and costs, as well as providing the reliability and functionality to deliver a better performance









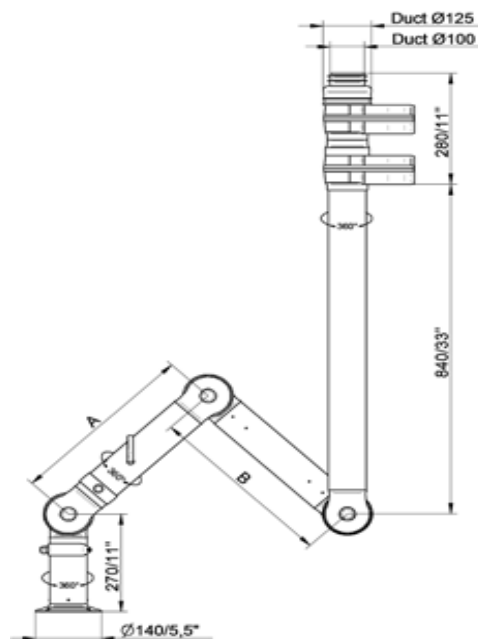

• FX2-CHEM-D100-L1200-Up-PLUS  
Part number: 70605744  
Max. working radius: 1170 mm (46,1 in)  
A: 450 mm (17,7 in)  
B: 450 mm (17,7 in)

• FX2-CHEM-D100-L1800-Up-PLUS  
Part number: 70606044  
Max. working radius: 1770 mm (69,7 in)  
A: 750 mm (29,5 in)  
B: 750 mm (29,5 in)

• FX2-CHEM-D100-L2400-Up-PLUS  
Part number: 70606444  
Max. working radius: 2290 mm (90,2 in)  
A: 1010 mm (39,7 in)  
B: 1010 mm (39,7 in)



## Models

|                                                                                   | Description                         | Weight (kg) | Item Number |
|-----------------------------------------------------------------------------------|-------------------------------------|-------------|-------------|
|  | FX2-CHEM-D100-L1200-Up/Down-Through | 4,8         | 70605644    |
|  | FX2-CHEM-D100-L1200-Up-PLUS         | 5,9         | 70605744    |
|  | FX2-CHEM-D100-L1800-Up-Low          | 4,1         | 70605844    |
|  | FX2-CHEM-D100-L1800-Down-Through    | 5,9         | 70605944    |
|  | FX2-CHEM-D100-L1800-Up-PLUS         | 7,7         | 70606044    |
|  | FX2-ESD/EX-D100-L1200-Up/Down-Low   | 5,9         | 70606144    |
|  | FX2-CHEM-D100-L2400-Up-Low          | 5,9         | 70606244    |
|  | FX2-ESD/EX-D100-L1800-Up-Low        | 6,9         | 70606344    |
|  | FX2-CHEM-D100-L2400-Up-PLUS         | 8,7         | 70606444    |

## Accessories

|                                                                                     |                                     | Item Number |
|-------------------------------------------------------------------------------------|-------------------------------------|-------------|
|  | FX2-Duct connector-ORIG/CHEM-D100   | 70377040    |
|  | FX2-Bench bracket kit-D50/75/100    | 70501444    |
|  | FX-Ceiling cover plate              | 70502644    |
|  | FX2-Ceiling cover plate-PLUS        | 70377045    |
|  | FX2-Bracket kit-D50/75/100-L500     | 70377042    |
|  | FX2-Wall BRKT kit-Flat-L190-White   | 70377043    |
|  | FX-Bracket kit-D50/75/100-L190      | 70501144    |
|  | FX2-Wall-P BRKT kit-D50/75/100-L190 | 70377046    |
|  | FX-Classic bracket-D50/75/100       | 70501244    |
|  | FX-Cut2fit extension-L1100          | 70501344    |
|  | FX-Cut2fit extension-L2200          | 70374600    |
|  | FX2-Hose support ring-D100          | 70377068    |
|  | FX2-Hose support ring-D125          | 70377069    |
|  | FX-Dome hood-CHEM-D50/75/100        | 70376984    |
|  | FX-Combi hood-CHEM-D50/75/100       | 70500344    |

|                                                                                   |                                     | Item Number |
|-----------------------------------------------------------------------------------|-------------------------------------|-------------|
|  | FX-Metal hood-ORIG/CHEM-D50/75/100  | 70500444    |
|  | FX-Flange hood-CHEM-D50/75/100      | 70503044    |
|  | FX2-Al duct-L1000-D75/100toD100-WHT | 70377054    |
|  | FX2-Al duct-L2000-D75/100toD100-WHT | 70377055    |
|  | FX-Hose-D100-L3000-Grey             | 70377099    |
|  | FX-Hose D125-L5000-Grey             | 70377100    |

# BenchTop Extraction Arm FX2 75 ESD/EX

The best and most cost-efficient solution for extraction of hazardous airborne contaminants, in applications where small, flexible and easy-to-use arms are required.

Nederman FX2 arms are made of lightweight anodized aluminium sections, with two or three adjustable, composite friction joints. Offering strength and durability combined with easy handling, they can be used in many types of environment. They are especially suitable for applications where small, flexible and easy-to-use arms are required. The arm is designed for use in electronic environments where there is a risk of electrostatic discharges. The ESD/EX can also be used for certain applications in potentially explosive atmospheres.

- Optimal efficiency and low noise provides safe and quiet working environment
- Ceilings, walls and floors or fixed to worktops mountings and cut2fit extension profile gives maximum installation flexibility
- The two outermost arm joints can rotate and swivel through 360°, which gives the unique maneuverability
- The lean, smooth and aesthetic design allows arms to fit in well in any environment without compromising its durability and reliability
- Highly integrated products that save customers' time and costs, as well as providing the reliability and functionality to deliver a better performance



## Material:



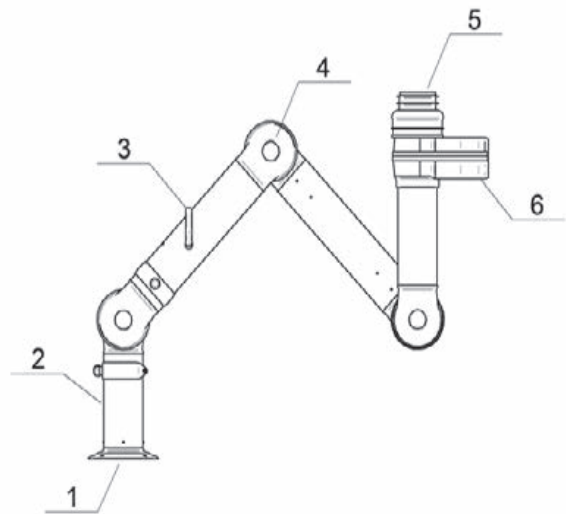















- 1) Flange: Conductive PP plastic
- 2) Tubes: Aluminum, anodized 10 µm
- 3) Damper adjustment handle: Aluminum: anodized 10 µm  
Internal spring: Stainless steel  
Damper blade: Conductive TP & PP plastic
- 4) Joints conductive: PP plastic with glass fibre reinforcement  
Plastic rings conductive: PP plastic with glass fibre reinforcement  
Axial locking rings conductive: PP plastic with glass fibre reinforcement  
Adjustment knobs: PA & EDS plastic  
Threaded shaft inside joints: Stainless Steel
- 5) Duct connector: conductive EPDM Rubber
- 6) Swivel: Aluminum, conductive powder coating  
Rivets: Aluminum  
Bearings swivel conductive: PP plastic with glass fibre reinforcement





## Models

|                                                                                   | Description                       | Weight (kg) | Item Number |
|-----------------------------------------------------------------------------------|-----------------------------------|-------------|-------------|
|  | FX2-ESD/EX-D75-L1100-Down-Low     | 3,2         | 70603944    |
|  | FX2-ESD/EX-D75-L1100-Down-Through | 3,2         | 70604144    |
|  | FX2-CHEM-D75-L1500-Up-Low         | 2,6         | 70604244    |
|  | FX2-ESD/EX-D75-L1500-Down-Through | 3,4         | 70604344    |
|  | FX2-ORIG-D100-L1800-Up-Low        | 3,4         | 70604544    |
|  | FX2-ORIG-D100-L1800-Down-Low      | 2,8         | 70604644    |

## Accessories

|                                                                                     |                                   | Item Number |
|-------------------------------------------------------------------------------------|-----------------------------------|-------------|
|    | FX2-Bench bracket kit-D50/75/100  | 70501444    |
|    | FX-Ceiling cover plate            | 70502644    |
|   | FX2-Ceiling cover plate-PLUS      | 70377045    |
|  | FX2-Bracket kit-D50/75/100-L500   | 70377042    |
|  | FX2-Wall BRKT kit-Flat-L190-Black | 70377044    |
|  | FX-Bracket kit-D50/75/100-L190    | 70501144    |
|  | FX-Cut2fit extension-L1100        | 70501344    |
|  | FX-Cut2fit extension-L2200        | 70374600    |
|  | FX-Classic bracket-D50/75/100     | 70501244    |
|  | FX-Dome hood-ESD/EX-D50/75/100    | 70376983    |
|  | FX-Combi hood-ESD/EX-D50/75/100   | 70500244    |
|  | FX-Metal hood-ESD/EX-D50/75/100   | 70500544    |
|  | FX-Flange hood-ESD/EX-D50/75/100  | 70502944    |
|  | FX2-Al duct-L1000-D75/100toD100   | 70377058    |
|  | FX2-Al duct-L2000-D75/100toD100   | 70377059    |
|  | FX2-Hose support ring-D75         | 70377067    |
|  | FX2-Hose support ring-D100        | 70377068    |
|  | FX-Hose-ESD-D75-L3000-Black       | 70377101    |

|                                                                                   |                               | Item Number |
|-----------------------------------------------------------------------------------|-------------------------------|-------------|
|  | FX-Hose-ESD-D100-L3000-Black  | 70377102    |
|  | FX2-Duct connector-ESD/EX-D75 | 70377039    |

# BenchTop Extraction Arm FX2 100 ESD/EX

The best and most cost-efficient solution for extraction of hazardous airborne contaminants, in applications where small, flexible and easy-to-use arms are required.

Nederman FX2 arms are made of lightweight anodized aluminium sections, with two or three adjustable, composite friction joints. Offering strength and durability combined with easy handling, they can be used in many types of environment. They are especially suitable for applications where small, flexible and easy-to-use arms are required. The arm is designed for use in electronic environments where there is a risk of electrostatic discharges. The ESD/EX can also be used for certain applications in potentially explosive atmospheres.

- Optimal efficiency and low noise provides safe and quiet working environment
- Ceilings, walls and floors or fixed to worktops mountings and cut2ft extension profile gives maximum installation flexibility
- The two outermost arm joints can rotate and swivel through 360°, which gives the unique maneuverability
- The lean, smooth and aesthetic design allows arms to fit in well in any environment without compromising its durability and reliability
- Highly integrated products that save customers' time and costs, as well as providing the reliability and functionality to deliver a better performance



## Material:



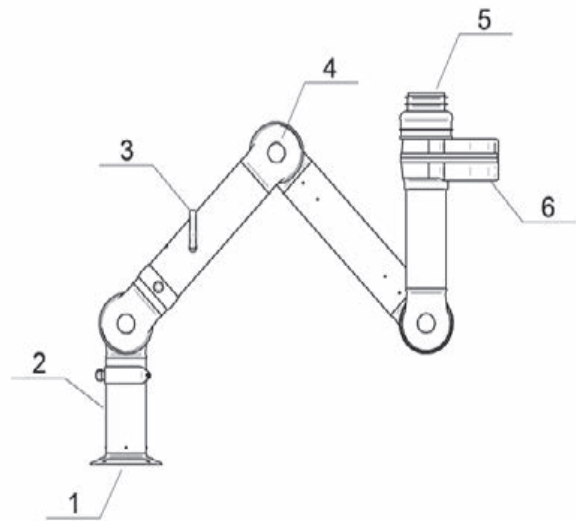













- 1) Flange: Conductive PP plastic
- 2) Tubes: Aluminum, anodized 10 µm
- 3) Damper adjustment handle: Aluminum: anodized 10 µm  
Internal spring: Stainless steel  
Damper blade: Conductive TP & PP plastic
- 4) Joints conductive: PP plastic with glass fibre reinforcement  
Plastic rings conductive: PP plastic with glass fibre reinforcement  
Axial locking rings conductive: PP plastic with glass fibre reinforcement  
Adjustment knobs: PA & EDS plastic  
Threaded shaft inside joints: Stainless Steel
- 5) Duct connector: conductive EPDM Rubber
- 6) Swivel: Aluminum, conductive powder coating  
Rivets: Aluminum  
Bearings swivel conductive: PP plastic with glass fibre reinforcement





## Models

|                                                                                   | Description                                                                                                                                                                                              | Weight (kg) | Item Number |
|-----------------------------------------------------------------------------------|----------------------------------------------------------------------------------------------------------------------------------------------------------------------------------------------------------|-------------|-------------|
|  | FX2-ESD/EX-D100-L1200-Up/Down-Thru                                                                                                                                                                       | 4,8         | 70606544    |
|  | FX2-ESD/EX-D100-L1800-Down-Low                                                                                                                                                                           | 4,1         | 70606744    |
|  | FX2-ORIG-D100-L1800-Down-Through                                                                                                                                                                         | 5,9         | 70606844    |
|  | FX2-ESD/EX-D100-L2400-Up-Low                                                                                                                                                                             | 5,9         | 70607044    |
|  | FX2-Duct connector-ORIG/CHEM-D50.<br>Grey duct connector to ease the coupling of 77 mm Alu duct to external 80 mm ductwork. Please note all arms are already supplied with a duct connector as standard. | 5,2         | 70607144    |
|  | FX2-ESD/EX-D100-L1800-Down-Through                                                                                                                                                                       | 6,9         | 70607244    |

## Accessories

|                                                                                     |                                   | Item Number |
|-------------------------------------------------------------------------------------|-----------------------------------|-------------|
|    | FX2-Duct connector-ESD/EX-D100    | 70377041    |
|    | FX2-Bench bracket kit-D50/75/100  | 70501444    |
|   | FX-Ceiling cover plate            | 70502644    |
|  | FX2-Ceiling cover plate-PLUS      | 70377045    |
|  | FX2-Bracket kit-D50/75/100-L500   | 70377042    |
|  | FX2-Wall BRKT kit-Flat-L190-Black | 70377044    |
|  | FX-Bracket kit-D50/75/100-L190    | 70501144    |
|  | FX-Classic bracket-D50/75/100     | 70501244    |
|  | FX-Cut2fit extension-L1100        | 70501344    |
|  | FX-Cut2fit extension-L2200        | 70374600    |
|  | FX-Dome hood-ESD/EX-D50/75/100    | 70376983    |
|  | FX-Combi hood-ESD/EX-D50/75/100   | 70500244    |
|  | FX-Metal hood-ESD/EX-D50/75/100   | 70500544    |
|  | FX-Flange hood-ESD/EX-D50/75/100  | 70502944    |
|  | FX2-Al duct-L1000-D75/100toD100   | 70377058    |
|  | FX2-Al duct-L2000-D75/100toD100   | 70377059    |
|  | FX2-Hose support ring-D100        | 70377068    |

|                                                                                   |                              | Item Number |
|-----------------------------------------------------------------------------------|------------------------------|-------------|
|  | FX2-Hose support ring-D125   | 70377069    |
|  | FX-Hose-ESD-D100-L3000-Black | 70377102    |
|  | FX-Hose-ESD-D125-L5000-Black | 70377103    |

# BenchTop Extraction Arm FX2 75 Original

The best and most cost-efficient solution for extraction of hazardous airborne contaminants, in applications where small, flexible and easy-to-use arms are required.

Nederman FX2 arms are made of lightweight anodized aluminium sections, with three adjustable, composite friction joints. Offering strength and durability combined with easy handling, they can be used in many types of environment. They are especially suitable for applications where small, flexible and easy-to-use arms are required. A robust and reliable all-round arm for general applications where there is little risk of electrical discharges or attack by aggressive chemicals.

- Optimal efficiency and low noise provides safe and quiet working environment
- Ceilings, walls and floors or fixed to worktops mountings and cut2fit extension profile gives maximum installation flexibility
- The two outermost arm joints can rotate and swivel through 360°, which gives the unique maneuverability
- The lean, smooth and aesthetic design allows arms to fit in well in any environment without compromising its durability and reliability
- Highly integrated products that save customers' time and costs, as well as providing the reliability and functionality to deliver a better performance







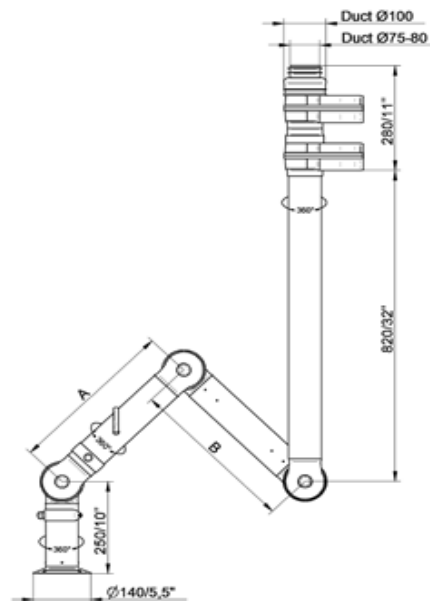



*FX2-ORIG-D75-L1100-Up-PLUS*  
Part number: 70602444  
Max. working radius: 1090 mm (42,9 in)  
A: 420 mm (16,5 in)  
B: 420 mm (16,5 in)

















• *FX2-ORIG-D75-L1500-Up-PLUS*  
Part number: 70602844  
Max. working radius: 1450 mm (57,1 in)  
A: 500 mm (19,7 in)  
B: 700 mm (27,5 in)







## Models

|                                                                                   | Description                                                                                        | Weight (kg) | Item Number |
|-----------------------------------------------------------------------------------|----------------------------------------------------------------------------------------------------|-------------|-------------|
|  | FX2-ORIG-D75-L1100-Down-Low                                                                        | 3,2         | 70602344    |
|  | FX2-ORIG-D75-L1100-Up-PLUS                                                                         | 4,5         | 70602444    |
|  | FX2-ORIG-D75-L1100-Down-Through                                                                    | 3,2         | 70602544    |
|  | High capacity HEPA-filter kit for FC:<br>4 pcs distance holders and 1 pc HEPA filter 610x610x292mm | 2,6         | 70602644    |
|  | FX2-ORIG-D75-L1500-Down-Low                                                                        | 3,4         | 70602744    |
|  | FX2-ORIG-D75-L1500-Up-PLUS                                                                         | 4,7         | 70602844    |
|  | FX2-ORIG-D75-L1500-Down-Through                                                                    | 3,4         | 70602944    |
|  | FX2-CHEM-D75-L1500-Down-Low                                                                        | 2,8         | 70603044    |

## Accessories

|                                                                                     |                                     | Item Number |
|-------------------------------------------------------------------------------------|-------------------------------------|-------------|
|   | FX2-Bench bracket kit-D50/75/100    | 70501444    |
|  | FX-Ceiling cover plate              | 70502644    |
|  | FX2-Ceiling cover plate-PLUS        | 70377045    |
|  | FX2-Wall BRKT kit-Flat-L190-White   | 70377043    |
|  | FX2-Bracket kit-D50/75/100-L500     | 70377042    |
|  | FX-Bracket kit-D50/75/100-L190      | 70501144    |
|  | FX2-Wall-P BRKT kit-D50/75/100-L190 | 70377046    |
|  | FX-Classic bracket-D50/75/100       | 70501244    |
|  | FX-Cut2fit extension-L1100          | 70501344    |
|  | FX-Cut2fit extension-L2200          | 70374600    |
|  | FX-Metal hood-ORIG/CHEM-D50/75/100  | 70500444    |
|  | FX2-Hose support ring-D75           | 70377067    |
|  | FX2-Hose support ring-D100          | 70377068    |
|  | FX-Dome hood-ORIGINAL-D50/75/100    | 70376982    |
|  | FX-Combi hood-ORIGINAL-D50/75/100   | 70500144    |
|  | FX-Flange hood-ORIGINAL-D50/75/100  | 70502844    |

|                                                                                   |                                   | Item Number |
|-----------------------------------------------------------------------------------|-----------------------------------|-------------|
|  | FX2-Al duct-L1000-D75/100toD100   | 70377058    |
|  | FX2-Al duct-L2000-D75/100toD100   | 70377059    |
|  | FX-Hose-D75-L3000-Grey            | 70377098    |
|  | FX-Hose-D100-L3000-Grey           | 70377099    |
|  | FX2-Duct connector-ORIG/CHEM-D100 | 70377040    |

# BenchTop Extraction Arm FX2 100 Original

The best and most cost-efficient solution for extraction of hazardous airborne contaminants, in applications where small, flexible and easy-to-use arms are required.

Nederman FX2 arms are made of lightweight anodized aluminium sections, with three adjustable, composite friction joints. Offering strength and durability combined with easy handling, they can be used in many types of environment. They are especially suitable for applications where small, flexible and easy-to-use arms are required. A robust and reliable all-round arm for general applications where there is little risk of electrical discharges or attack by aggressive chemicals.

- Optimal efficiency and low noise provides safe and quiet working environment
- Ceilings, walls and floors or fixed to worktops mountings and cut2fit extension profile gives maximum installation flexibility
- The two outermost arm joints can rotate and swivel through 360°, which gives the unique maneuverability
- The lean, smooth and aesthetic design allows arms to fit in well in any environment without compromising its durability and reliability
- Highly integrated products that save customers' time and costs, as well as providing the reliability and functionality to deliver a better performance



*FX2-ORIG-D100-L1200-Up-PLUS*

*Part number: 70604844*

*Max. working radius: 1170 mm (46,1 in)*

*A: 450 mm (17,7 in)*

*B: 450 mm (17,7 in)*

• *FX2-ORIG-D100-L1800-Up-PLUS*

*Part number: 70605144*

*Max. working radius: 1770 mm (69,7 in)*

*A: 750 mm (29,5 in)*

*B: 750 mm (29,5 in)*

• *FX2-ORIG-D100-L2400-Up-PLUS*

*Part number: 70605544*







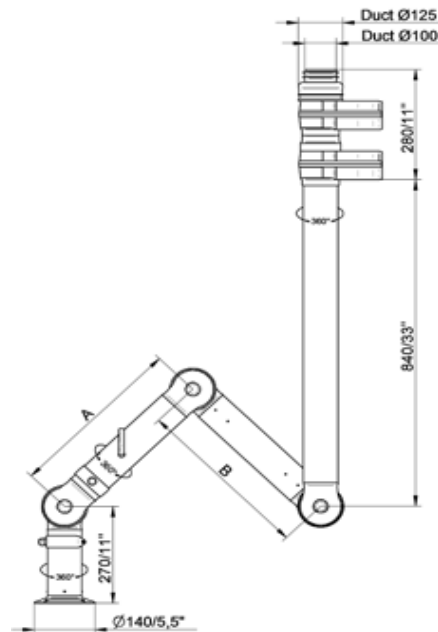

*Max. working radius: 2290 mm (90,2 in)*

*A: 1010 mm (39,7 in)*

*B: 1010 mm (39,7 in)*



## Models

|                                                                                   | Description                     | Weight (kg) | Item Number |
|-----------------------------------------------------------------------------------|---------------------------------|-------------|-------------|
|  | FX2-ORIG-D100-L1200-Up/Down-Thr | 4,8         | 70604744    |
|  | FX2-ORIG-D100-L1200-Up-PLUS     | 5,9         | 70604844    |
|  | FX2-ESD/EX-D75-L1500-Up-Low     | 4,1         | 70604944    |
|  | FX2-ORIG-D100-L1200-Up/Down-Low | 5,9         | 70605044    |
|  | FX2-ORIG-D100-L1800-Up-PLUS     | 7,7         | 70605144    |
|  | FX2-ORIG-D100-L2400-Up-Low      | 5,9         | 70605244    |
|  | FX2-CHEM-D100-L1800-Down-Low    | 5,2         | 70605344    |
|  | FX2-CHEM-D100-L1200-Up/Down-Low | 6,9         | 70605444    |
|  | FX2-ORIG-D100-L2400-Up-PLUS     | 8,7         | 70605544    |

## Accessories

|                                                                                     |                                     | Item Number |
|-------------------------------------------------------------------------------------|-------------------------------------|-------------|
|  | FX2-Duct connector-ORIG/CHEM-D100   | 70377040    |
|  | FX2-Bench bracket kit-D50/75/100    | 70501444    |
|  | FX-Ceiling cover plate              | 70502644    |
|  | FX2-Ceiling cover plate-PLUS        | 70377045    |
|  | FX2-Bracket kit-D50/75/100-L500     | 70377042    |
|  | FX2-Wall BRKT kit-Flat-L190-White   | 70377043    |
|  | FX-Bracket kit-D50/75/100-L190      | 70501144    |
|  | FX2-Wall-P BRKT kit-D50/75/100-L190 | 70377046    |
|  | FX-Classic bracket-D50/75/100       | 70501244    |
|  | FX-Cut2fit extension-L1100          | 70501344    |
|  | FX-Cut2fit extension-L2200          | 70374600    |
|  | FX-Dome hood-ORIGINAL-D50/75/100    | 70376982    |
|  | FX-Combi hood-ORIGINAL-D50/75/100   | 70500144    |
|  | FX-Metal hood-ORIG/CHEM-D50/75/100  | 70500444    |
|  | FX-Flange hood-ORIGINAL-D50/75/100  | 70502844    |

|                                                                                   |                                 | Item Number |
|-----------------------------------------------------------------------------------|---------------------------------|-------------|
|  | FX2-Al duct-L1000-D75/100toD100 | 70377058    |
|  | FX2-Al duct-L2000-D75/100toD100 | 70377059    |
|  | FX2-Hose support ring-D100      | 70377068    |
|  | FX2-Hose support ring-D125      | 70377069    |
|  | FX-Hose-D100-L3000-Grey         | 70377099    |
|  | FX-Hose D125-L5000-Grey         | 70377100    |

# BenchTop Extraction Arm FX2 50 Original

The best and most cost-efficient solution for extraction of hazardous airborne contaminants, in applications where small, flexible and easy-to-use arms are required.

Nederman FX2 arms are made of lightweight anodized aluminium sections, with two or three adjustable, composite friction joints. Offering strength and durability combined with easy handling, they can be used in many types of environment. They are especially suitable for applications where small, flexible and easy-to-use arms are required. A robust and reliable all-round arm for general applications where there is little risk of electrical discharges or attack by aggressive chemicals.

- Optimal efficiency and low noise provides safe and quiet working environment
- Ceilings, walls and floors or fixed to worktops mountings and cut2fit extension profile gives maximum installation flexibility
- The two outermost arm joints can rotate and swivel through 360°, which gives the unique maneuverability
- The lean, smooth and aesthetic design allows arms to fit in well in any environment without compromising its durability and reliability
- Highly integrated products that save customers' time and costs, as well as providing the reliability and functionality to deliver a better performance









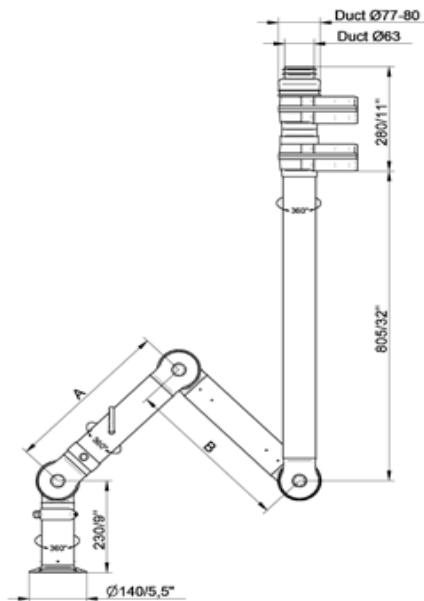



• FX2-ORIG-D50-L700-Up-PLUS  
Part number: 70600244  
Max. working radius: 630 mm (24,8 inch)  
A: 400 mm (15,7 in)

• FX2-ORIG-D50-L1100-Up-PLUS  
Part number: 70600544  
Max. working radius: 1030 mm (40,5 in)  
A: 400 mm (15,75in)  
B: 400 mm (15,7 in)

• FX2-ORIG-D50-L1500-Up-PLUS  
Part number: 70600944  
Max. working radius: 1430 mm (56,3 in)  
A: 500 mm (19,7 in)  
B: 700 mm (27,6 in)



## Models

|                                                                                   | Description                                          | Weight (kg) | Item Number |
|-----------------------------------------------------------------------------------|------------------------------------------------------|-------------|-------------|
|  | Frequency Inverter 2,2 kW incl transmitter 0 - 2 kPa | 1,7         | 70600144    |
|  | FX2-ORIG-D50-L700-Up-PLUS                            | 2,7         | 70600244    |
|  | FX2-ORIG-D50-L1100-Down-Through                      | 1,2         | 70600344    |
|  | FX2-ORIG-D50-L1100-Down-Low                          | 2,3         | 70600444    |
|  | FX2-ORIG-D50-L1100-Up-PLUS                           | 3,3         | 70600544    |
|  | FX2-ESD/EX-D50-L700-Up/Down-Low                      | 2,3         | 70600644    |
|  | FX2-ORIG-D50-L1500-Up-Low                            | 1,8         | 70600744    |
|  | FX2-ORIG-D50-L1500-Down-Low                          | 2,6         | 70600844    |
|  | FX2-ORIG-D50-L1500-Up-PLUS                           | 3,6         | 70600944    |
|  | FX2-ORIG-D50-L1500-Down-Through                      | 2,6         | 70601044    |
|  | FX2-ORIG-D50-L1100-Up-Low                            | 2,1         | 70601144    |

## Accessories

|                                                                                     |                                     | Item Number |
|-------------------------------------------------------------------------------------|-------------------------------------|-------------|
|  | FX-Bracket kit-D50/75/100-L190      | 70501144    |
|  | FX-Classic bracket-D50/75/100       | 70501244    |
|  | FX-Cut2fit extension-L1100          | 70501344    |
|  | FX2-Bench bracket kit-D50/75/100    | 70501444    |
|  | FX-Metal hood-ORIG/CHEM-D50/75/100  | 70500444    |
|  | FX-Ceiling cover plate              | 70502644    |
|  | FX-Flange hood-ORIGINAL-D50/75/100  | 70502844    |
|  | FX-Cut2fit extension-L2200          | 70374600    |
|  | FX-Dome hood-ORIGINAL-D50/75/100    | 70376982    |
|  | FX2-Bracket kit-D50/75/100-L500     | 70377042    |
|  | FX2-Ceiling cover plate-PLUS        | 70377045    |
|  | FX2-Wall BRKT kit-Flat-L190-White   | 70377043    |
|  | FX2-Wall-P BRKT kit-D50/75/100-L190 | 70377046    |

|                                                                                   |                                   | Item Number |
|-----------------------------------------------------------------------------------|-----------------------------------|-------------|
|  | FX-Combi hood-ORIGINAL-D50/75/100 | 70500144    |
|  | FX2-AI duct-L1000-D50toD77        | 70377056    |
|  | FX2-AI duct-L2000-D50toD77        | 70377057    |
|  | FX2-Hose support ring-D75         | 70377067    |
|  | FX-Hose-D75-L3000-Grey            | 70377098    |
|  | FX2-Duct connector-ORIG/CHEM-D50  | 70377036    |

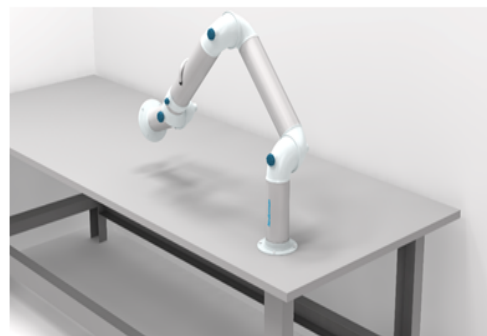
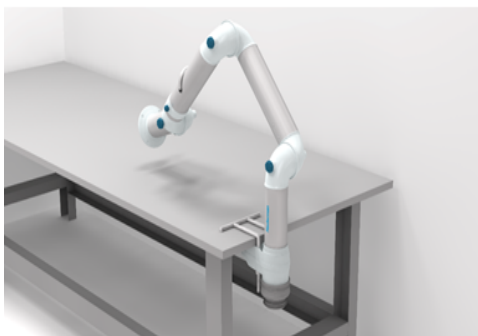

# Bench Top Extraction arm FX32 Original

## Flexible bench top extraction arm



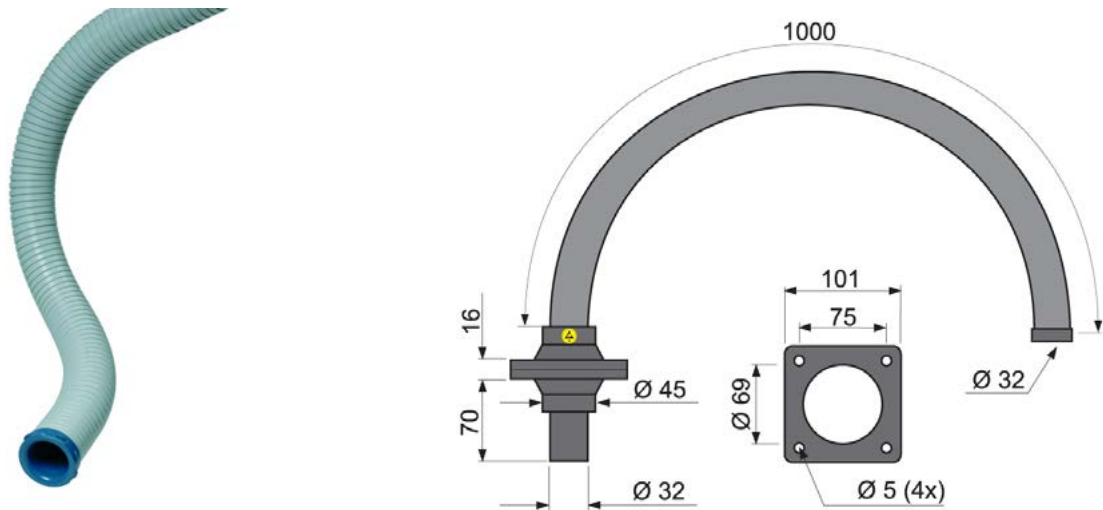

Extractor arms for use in industries, laboratories, schools etc. Flexible plastic hose with a very good resistancy against solvents etc. Stays in new position when adjusted. Swivel with 360 degree rotation. This means that the connected ductwork remains firm and does not rotate with the arm. Mounting directly in bench surface or with accessory brackets. Can be mounted both standing and hanging.



## Models

|                                                                                     | Arm length (m) | Description                   | Item Number |
|-------------------------------------------------------------------------------------|----------------|-------------------------------|-------------|
|  | 0,85           | FX 32 Extraction arm Original | 70502834    |

## Accessories

|                                                                                     |                                    | Item Number |
|-------------------------------------------------------------------------------------|------------------------------------|-------------|
|  | Flange hood for FX 32 standard     | 70371525    |
|  | Wall bracket FX 32 Std/ESD/PP      | 70371760    |
|  | Dome hood 1/2 for FX 32 standard   | 70371756    |
|  | Dome hood 1/1 for FX 32 standard   | 70371757    |
|  | Table bracket, 75/50/32 Std/ESD/PP | 70371761    |

# Bench Top Extraction arm FX32 ESD

## Flexible bench top extraction arm



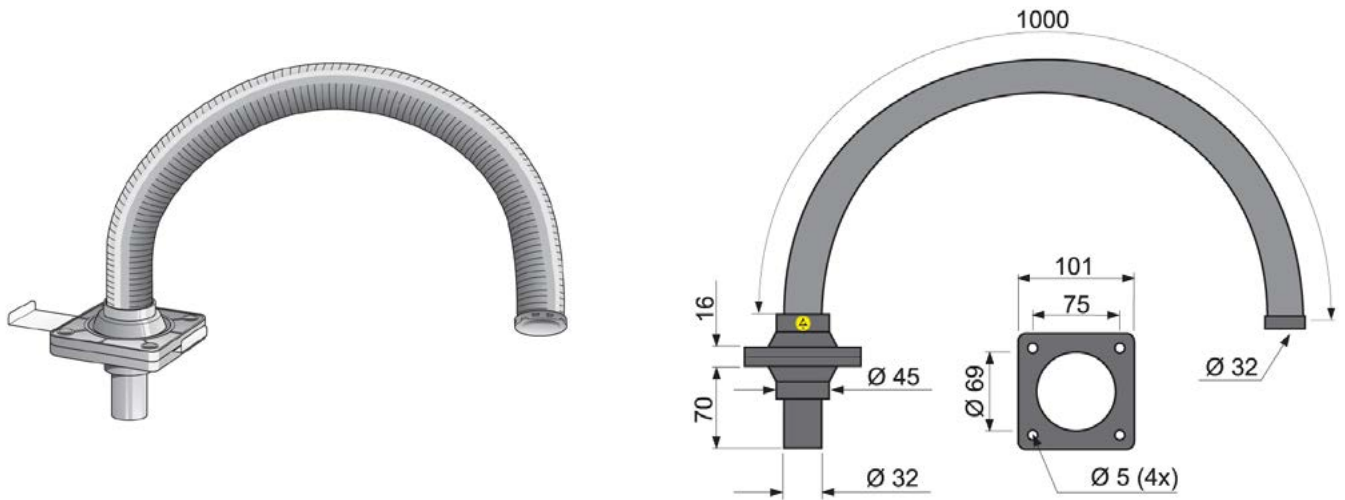

Extractor arms for use in electronic industries, laboratories, schools etc. Flexible plastic hose with a very good resistancy against solvents etc. Stays in new position when adjusted. ESD safe. Swivel with 360 degree rotation. This means that the connected ductwork remains firm and does not rotate with the arm. Mounting directly in bench surface or with accessory brackets. Can be mounted both standing and hanging.



## Models

|                                                                                     | Arm length (m) | Description              | Item Number |
|-------------------------------------------------------------------------------------|----------------|--------------------------|-------------|
|  | 0,85           | FX 32 extraction arm ESD | 70502934    |

## Accessories

|                                                                                     |                                    | Item Number |
|-------------------------------------------------------------------------------------|------------------------------------|-------------|
|  | Dome hood 1/2 for FX 32 ESD        | 70371807    |
|  | Dome hood 1/1 for FX 32 ESD        | 70371808    |
|  | Table bracket, 75/50/32 Std/ESD/PP | 70371761    |
|  | Wall bracket FX 32 Std/ESD/PP      | 70371760    |

## Contact info

Nederman Distribution Sales  
Dick Meiling  
dick.meiling@nederman.nl  
www.nederman.com

## About us

Nederman is a world-leading environmental technology company. We filter, clean and recycle to create eco-efficient production in demanding industrial surroundings.

For more than 70 years, Nederman has developed, manufactured and installed products and solutions to reduce the strain on the environment and improve working conditions in numerous industries.

Our products and systems have been ground-breaking in industries such as machining, metal fabrication, mining, automotive, composite manufacturing, food, pharmaceuticals, woodworking and many others.